

## Compact infrared camera for laser applications

### Features:

- Wide measurement range from 575 °C to 1900 °C without sub-ranges
- Special narrow-band spectral response at 800 nm ideal for almost all NIR and CO<sub>2</sub> laser processing applications
- High dynamic CMOS detector with up to 764 x 480 pixels resolution
- Up to 1 kHz frame rate for fast processes
- Real-time analog output with 1 ms response time
- Extensive software package and SDK included

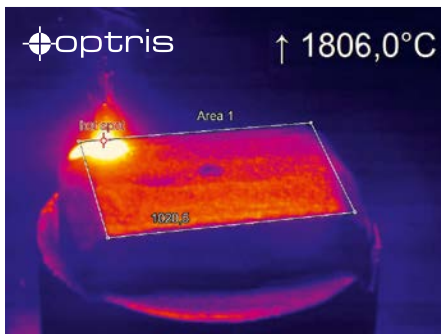
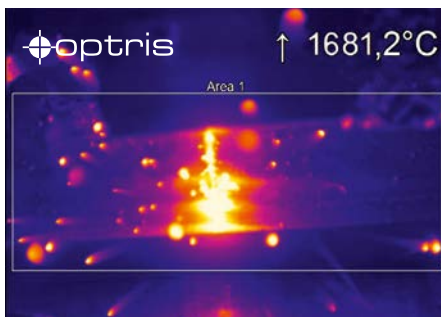

Image: SLV Halle GmbH, Deutschland 2018



For further information as well as the product configurator, please visit:  
[www.optris.global/thermal-imager-pi-08m](http://www.optris.global/thermal-imager-pi-08m)

### Technical specifications

Optical resolution (switchable)/ Frame rate	764 x 480 pixels @ 32 Hz 382 x 288 pixels @ 80 Hz (switchable to 27 Hz) 72 x 56 pixels @ 1 kHz <sup>1)</sup> 764 x 8 pixels @ 1 kHz (fast linescanning mode) <sup>1)</sup>	
Detector	CMOS (15 µm x 15 µm)	
Spectral range	780 – 820 nm	
Temperature range	575 °C ... 1900 °C (27 Hz mode) 625 °C ... 1900 °C (32 / 80 Hz mode) 750 °C ... 1900 °C (1 kHz mode)	
Optics	<b>FOV @ 764 x 480 px:</b> 20° x 15° (f = 16 mm) 26° x 16° (f = 25 mm)	<b>FOV @ 382 x 288 px:</b> 39° x 25° (f = 16 mm) 13° x 10° (f = 25 mm)
Thermal sensitivity (NETD)	< 2 K (<1000 °C/ 27 Hz to 1kHz) <sup>2)</sup>	
Accuracy	+/- 1 % of reading (<1500 °C)/ +/- 1,5 % of reading (>1500 °C) <sup>3)</sup>	
PC interface	USB 2.0 / optional USB to GigE (PoE) conversion	
High speed analog output (@ 1 kHz mode)	0–10 V real time output of 8x8 pixel (1 ms response time)	
Standard process interface (PIF)	0–10 V input, digital input (max. 24 V), 0–10 V output	
optional Industrial process interface (PIF)	2x 0–10 V inputs, digital input (max. 24 V), 3x 0/4–20 mA outputs, 3x relay (0–30 V/ 400 mA), fail-safe relay	
Cable length (USB)	1 m (standard), 5 m, 10 m, 20 m 5 m and 10 m also available as high temperature USB cable (180 or 250 °C)	
Ambient temperature	5 °C ... 50 °C	
Storage temperature	–40 °C ... 70 °C	
Relative humidity	20–80 %, non-condensing	
Enclosure (size/ rating)	46 x 56 x 88 – 129 mm (depending on lens + focus position) / IP 67 (NEMA 4) <sup>4)</sup>	
Weight	245 – 311 g (depending on lens)	
Shock / Vibration <sup>5)</sup>	IEC 60068-2-27 (25G and 50G) / IEC 60068-2-6 (sinus shaped), IEC 60068-2-64 (broadband noise)	
Tripod mount	¼–20 UNC	
Power supply	via USB	
Software	optris PIX Connect / IRmobile Android App	
Scope of supply (standard)	<ul style="list-style-type: none"> <li>• USB camera with 1 lens</li> <li>• Lens protection tube incl. protective window</li> <li>• USB cable (1 m)</li> <li>• Table tripod</li> </ul>	<ul style="list-style-type: none"> <li>• PIF cable (1 m) incl. terminal block</li> <li>• Software package optris PIX Connect</li> <li>• Aluminum case</li> <li>• Optional: CoolingJacket, HT cable</li> </ul>

<sup>1)</sup> Can be placed anywhere within the full FOV

<sup>2)</sup> <4 K (>1000 °C/ 27 Hz to 1 kHz)

<sup>3)</sup> for 1 kHz mode: +/- 1,5 % of reading (<1500 °C) / +/- 2 % of reading (>1500 °C)

<sup>4)</sup> Only applies when lens protection tube is used

<sup>5)</sup> For more details see operator's manual

# optris PI 08M

## Dimensions

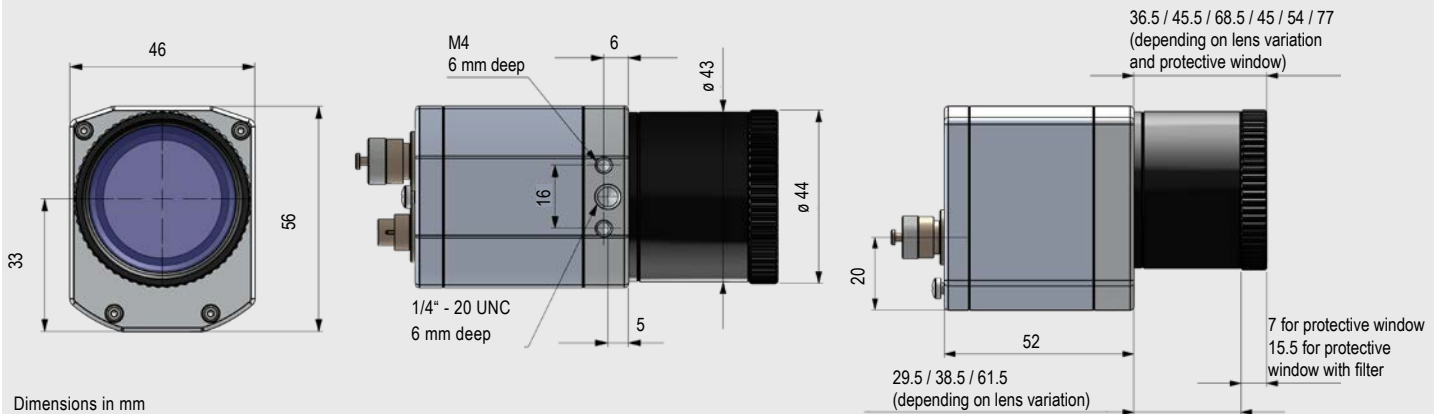

## Process integration

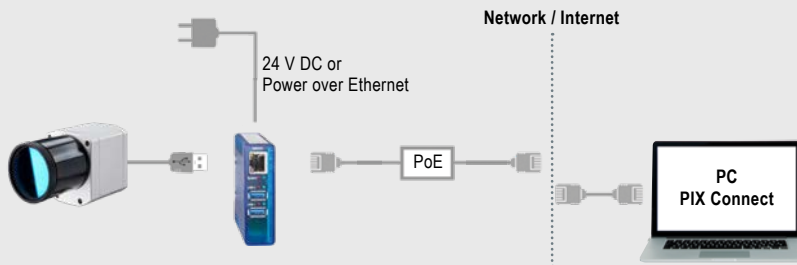

### optris USB Server Gigabit 2.0

- Network connection via Gigabit Ethernet
- Full TCP/IP support incl. routing and DNS
- Two independent USB ports
- Power over Ethernet or external voltage supply at 24 - 48 V DC
- Galvanic isolation 500 V<sub>RMS</sub>
- Remotely configurable via web based management

For further information please visit

[www.optris.global/usb-server-gigabit](http://www.optris.global/usb-server-gigabit)

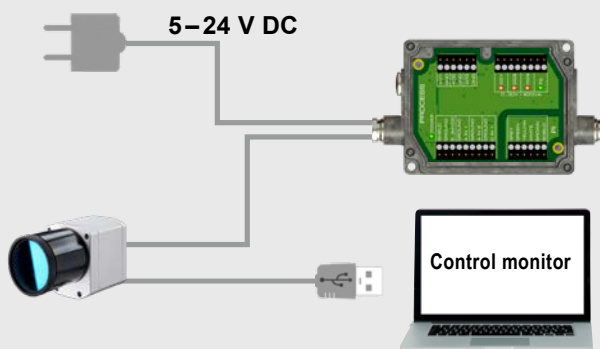

### optris Industrial process interface

- Use of camera for process monitoring in industrial environments
- Continuous fail safe monitoring of imager, software and cable connections
- 3 analog/ alarm outputs, 2 analog inputs, 1 digital input, 3 alarm relays, 1 fail-safe relay

For further information please visit

[www.optris.global/neu-industrial-process-interface](http://www.optris.global/neu-industrial-process-interface)

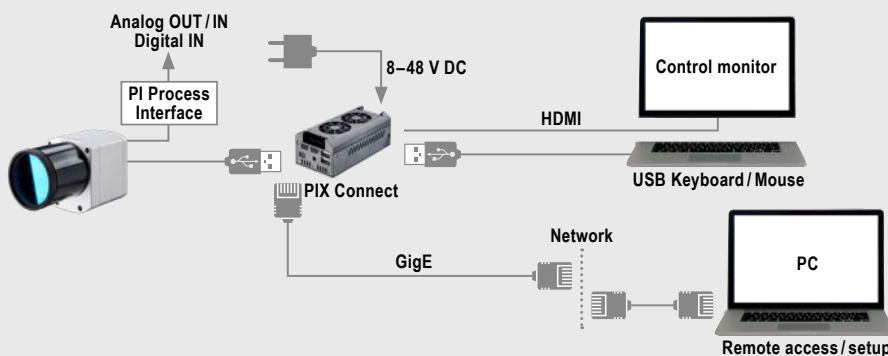

### optris PI NetBox

- Miniature PC as add-on to the PI series for stand-alone system
- Integrated hardware and software watchdog
- Connections: 2x USB 2.0, 1x USB 3.0, 1x Mini-USB 2.0, Micro-HDMI, Ethernet (Gigabit Ethernet), micro SDHC / SDXC card

For further information please visit

[www.optris.global/pi-netbox](http://www.optris.global/pi-netbox)